

DC SMART GRID CONNECTED WITH RING TOPOLOGY FUEL CHARGING STATION FOR EV, PHEV AND AC LOAD BY HYBRID MLI WITH EMS

Naveen Kumar R.

Adhiparasakthi Engineering College,
Melmaruvathur, Kancheepuram District, Tamil Nadu ,India.

Abstract

This paper presents the Solar (photo voltaic) power Plant and Windmill plant with DC Smart Grid connected with an DC Fuel Charging Station For Electric Vehicle (EV) , Plug in Hybrid Electric Vehicle (PHEV) and converted to AC load for Consumer single or Three phase ac load by means of Hybrid Multilevel Inverter(MLI). Solar Energy which store energy in lithium-ion battery and connected to Smart Grid .Wind Energy which get stored in Lithium-ion battery that Fixed DC Voltage connected with DC Smart Grid. Smart Grid which are Connected with DC Fuel Charging Station in Ring Topology with a certain distance for charging of Electric Vehicle(EV) and Plug-in Hybrid Electric Vehicle with On-Board(Integrated) Charger for faster charging of EV . In Power demand for Consumer the DC load from smart grid converted into an ac load by Hybrid Multilevel Inverter. In Consumers Place the small wind mill and PV panel are installed that energy can be used for consumers load at peak time or power Shutdown .Other than the power shutdown or peak time in the consumers place, stored DC Energy can be fed to Smart Grid. A major development in distribution automation is deployment of smart meters as a gateway between the utility and customer. With such capabilities the smart meter becomes not only a point of measurement of consumed kWh but also a controller capable of bidirectional communications with both the customer and utility.

Keywords—Electric Vehicle (EV), Plug-in Hybrid Multilevel Inverter(PHEV), Battery storage plants, carbon economy,dc-dc converter, high static gain, Hybrid energy, wind energy, solar energy.

I. INTRODUCTION

DC-DC converter are now emerging as an important research focus due to the demand of the fossil fuel and Petroleum cost for Electric Vehicle .For some applications as renewable energy sources, fuel-cells embedded systems portable electronic equipment's, uninterrupted power supply, battery powered systems ,Electric Vehicle and Plug in Hybrid Electric Vehicle with Smart Grid and other applications supplied by low DC voltage energy sources [1]. Renewable energy resources is an increasingly an important part of power generation in the new millennium [2]. There is an enormous need for integrated power converters that are capable of interfacing and controlling several power terminals with low cost and compact structure. Renewable energy sources do not have the high external cost and social issues. Renewable energy sources such as wind, solar, fuel cell holds more potential to meet our energy demands. This proposal focuses on two major renewable-energy sources: PV and wind energy with the DC Smart Grid Connected for the Fuel Charging Station for Electric Vehicle(EV),Plug in Hybrid Electric Vehicle(PHEV) and also at peak time in the consumer the DC Load is converted to AC by Hybrid MultiLevel

Inverter. High step up ratio is necessary when some loads operate with and DC or AC peak voltage higher than ten times of input source voltage.

II. HYBRID ENERGY

Hybrid Renewable Energy systems are becoming popular for remote area power generation due to advances in the renewable energy technologies and the subsequent rises in prices of petroleum Energy. A hybrid energy system usually consists of two or more renewable energy sources used together to provide increased system efficiency as well as greater balance in energy supply for longer life than the Thermal power plant with coal and petroleum and gas as a fuel.

A. Wind energy

Wind energy is the fastest-growing renewable source of clean energy. It has shown its great potential for combating climatic change, ensuring clean and efficient energy. It can make major contribution towards satisfying the global need for clean [2]. For modeling the energy produced by wind power, all components in the system is to be modeled. First the wind turbine has to be modeled, including the mechanical drive train, such as shafts, gearboxes and bearings. Second the

electrical machine, mostly a synchronous machine is modeled in detail and connected to a model of the power electronics, such as controlled rectifiers or back to back converters. Wind generation equipment is categorized into three general classifications:

- Utility-Scale – Corresponds to large turbines (900 kW to 2 MW per turbine) intended to generate bulk energy for sale in power markets. They are typically installed in large arrays or ‘wind energy projects,’ but can also be installed in small quantities on distribution lines, otherwise known as distributed generation. Utility scale development is the most common form of wind energy development in INDIA.
- Industrial-Scale – Corresponds to medium sized turbines (50 kW to 250 kW) intended for remote grid production, often in conjunction with diesel generation or load-side generation (on the customer’s side of the meter) to reduce consumption of

higher cost grid power and possibly to even reduce peak loads. Direct sale of energy to the local utility may or may not be allowed under state law or utility regulations.

- Residential-Scale – Corresponds to micro- and small-scale turbines (400 watts to 50kW) intended for remote power, battery charging, or net metering type generation. The small turbines can be used in conjunction with solar photo voltaics , batteries and inverters to provide constant power at remote locations where installation of a distribution line is not possible or is more expensive.

B. Solar energy

Photovoltaic (PV) offers an environmentally friendly source of electricity. Worldwide, photovoltaic account for 500 MW of power generation with an annual growth rate greater than 20% . In this module the solar cells is a fundamental power conversion unit of a photovoltaic system. The easy installation and maintenance free operational feature of the hybrid

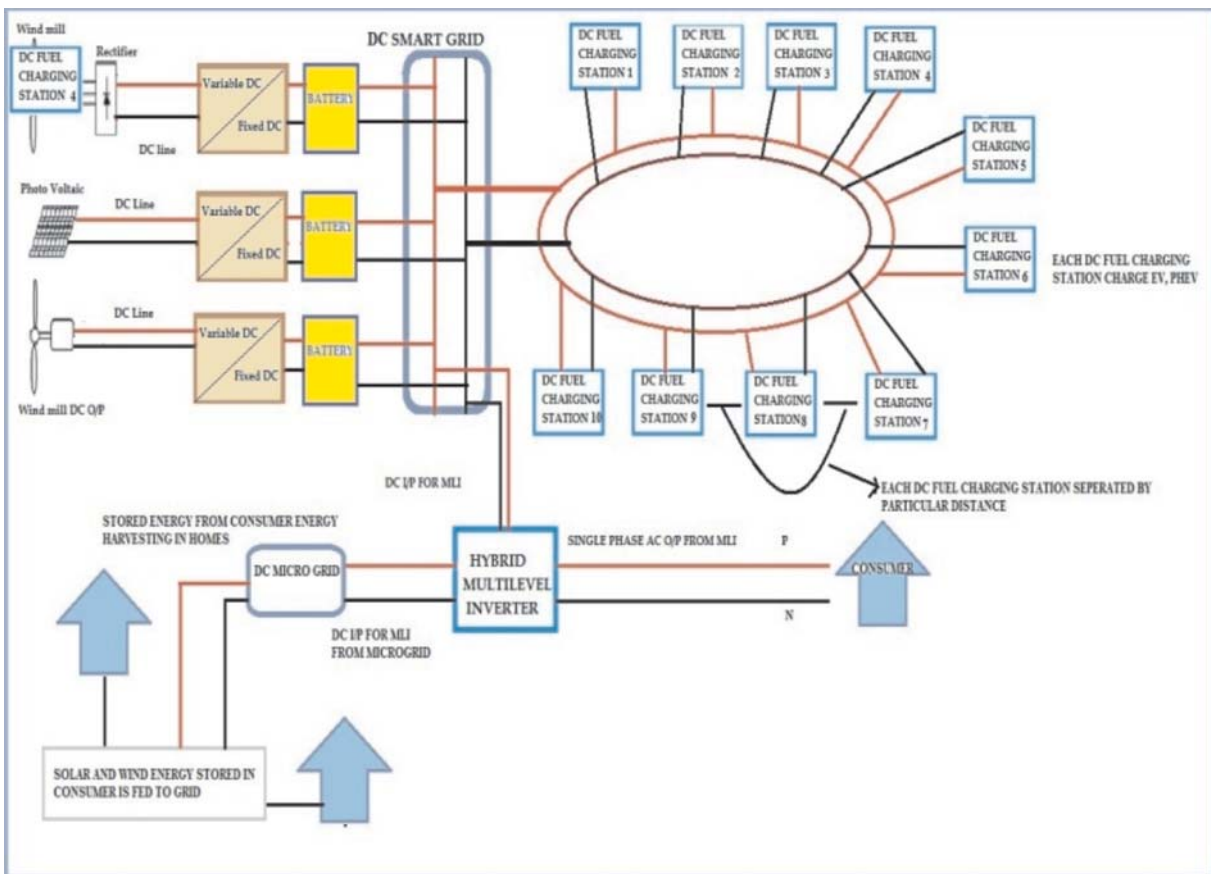

Fig. 1. Hybrid Energy Fed toDC SmartGrid Connected with DC Fuel Station for charging EV,PHEV.

system created more popularity among the rural masses.

Wind and solar power Energy are given as input to the Variable DC to Fixed DC Converter for getting an Fixed DC input to the Smart Grid DC. Each Renewable Energy is Connected with Battery for Storage and sends the energy to smart Grid When the Battery is Charged from the separate Renewable Energy. The output from converter is given to the DC Fuel Charging station which is connected in Ring Topologies with a Few Kilometers between a each DC Fuel Filling Station for the Electric Vehicle, Plug-in Hybrid Electric vehicle with faster charging by using the On-Board charger. At the time of Peak Load in the Consumer side then the power can fed from the DC Smart Grid By using an Hybrid Multilevel Inverter. At the Same Time When normal load time in the consumer area and then the Energy Stored from the Consumer through Small Windmill Turbine and Photovoltaic Cell. The Hybrid Multilevel inverter which converts dc to ac and is applied to load. The load used here is resistive load..

III. BATTERY

BATTERIES have a important role in the development of electric vehicles. Its energy density, power density, charging time, lifetime, and the cost are the challenges for commercialization and are still the subject of research. The charging time and lifetime of the battery have a strong dependence on the characteristics of the battery charger[11]-[12]. Various manufacturers are working on the development of various types of battery modules for electric vehicles (EVs) and hybrid Electric vehicles. Although, the performance of battery modules depends not only on the design of the battery modules but also on how the modules are discharged and charged. In this , battery chargers have a critical role in the development of this technology.

There are two types of battery chargers available : onboard charger type and stand-alone (off-board) charger type. However, the onboard charger gives easy to charge anywhere where there is an electric power outlet available. The onboard type has the only drawback of adding weight, volume, and cost to the vehicle by using onboard charger. And so, it is always made for lower powers (< 4.5 kW). When higher charging power for the vehicle is needed, then the size

and weight of the charger are easier to handle with an using off-board charger. Vehicles with a longer EV range (e.g., > 120 km) may require filling large amounts of energy (e.g., > 25 kWh) in a very short time. Even a 30-min charging time would require a charging power of 40 kW rmore, which is on the high side and very well may be limited by the maximum permitted continuous battery power. With a significantly increased use of EVs, the need for large charging times, compared to filling the gasoline, petrol, which Implies the need for an DC Fuel Station is high,stations, which will be expensive for the intial instalment Cost. Then there is high-power onboard chargers are attractive if when the weight, volume, and cost less .

If the volume,weight and cost is less , then the infrastructure requirement would be reduced to rather simple high-power outlets, and thus, the cost of these would be significantly lower than off-board chargers. There is a good possibility of avoiding these problems of additional charger weight, space, and cost by using available traction hardware, mainly by using the electric motor and the inverter, for the charger circuit Module, thus having integrated drive system and battery charger. The integration may also allow galvanic isolation. Other aspects to consider regarding integrated chargers are voltage level adaption, unwanted developed torque in the motor during charging, efficiency, low harmonic content in the current from the grid, and mandatory unity power factor operation. Different types of integrated chargers have been reported [12]–[14]. Both hardware and the control algorithms for the reviewed chargers are compared and described . Provided, a new isolated-high-power bidirectional battery charger is explained ,which combines the traction drive system components (converter and motor) [15], [16]–[18].

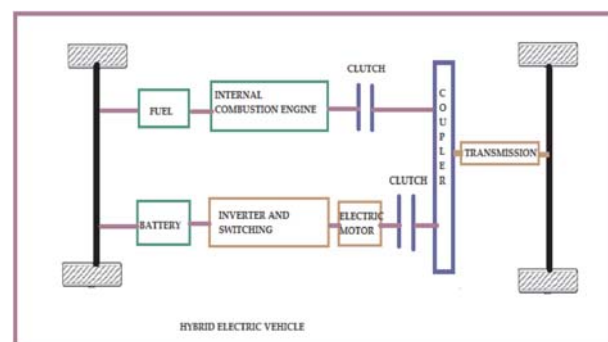

Fig. 2 Hybrid Electric Vehicle

IV. SMART GRID

Many new Technology made a changes in the electricity infrastructure including the modification of the existing smartgrid with microgrids and megagrids, and new Equipment exploring new materials and concepts ranging from superconductivity and nano material to highly flexible controllable and energy storage. Additionally, extensive sensors, communications, control system,data processing, visualization tools, and infrastructures are been installed. This leads to a smart grid concepts that initially explore the combining issues between new and previous solutions and infrastructures, which are the most expecting issues to be solved. The most important and complex integration issue is the full use of variable renewable generation, the electrification of the transportation sector.

This paper shows on some emerging and recent Trend projected to be widely used in the future. Examples of such technologies are residential /commercial / industrial / tility energy efficiency solutions, smart meters , synchro phasor systems,

energy management technique and systems, condition-based maintenance, EVs ,PHEVs, sustainable energy generation solutions, and energy storage [5]. Many of these emerging technologies are influenced by government subsidies. The application of these technology to the demand side management, distribution and transmission automation. The paper also discusses planning alternatives and a new planning that will give direction for future development of the power grid and that too will assure that the grid expansions are sustainable, cost effective, resilient, safe, and environmentally friendly .

A study to characterize the key smart grid attributes are:

- self-healing from the power disturbance events;
- enabling active participation by consumers in the demand response side;
- operating resiliently against physical and natural attacks.

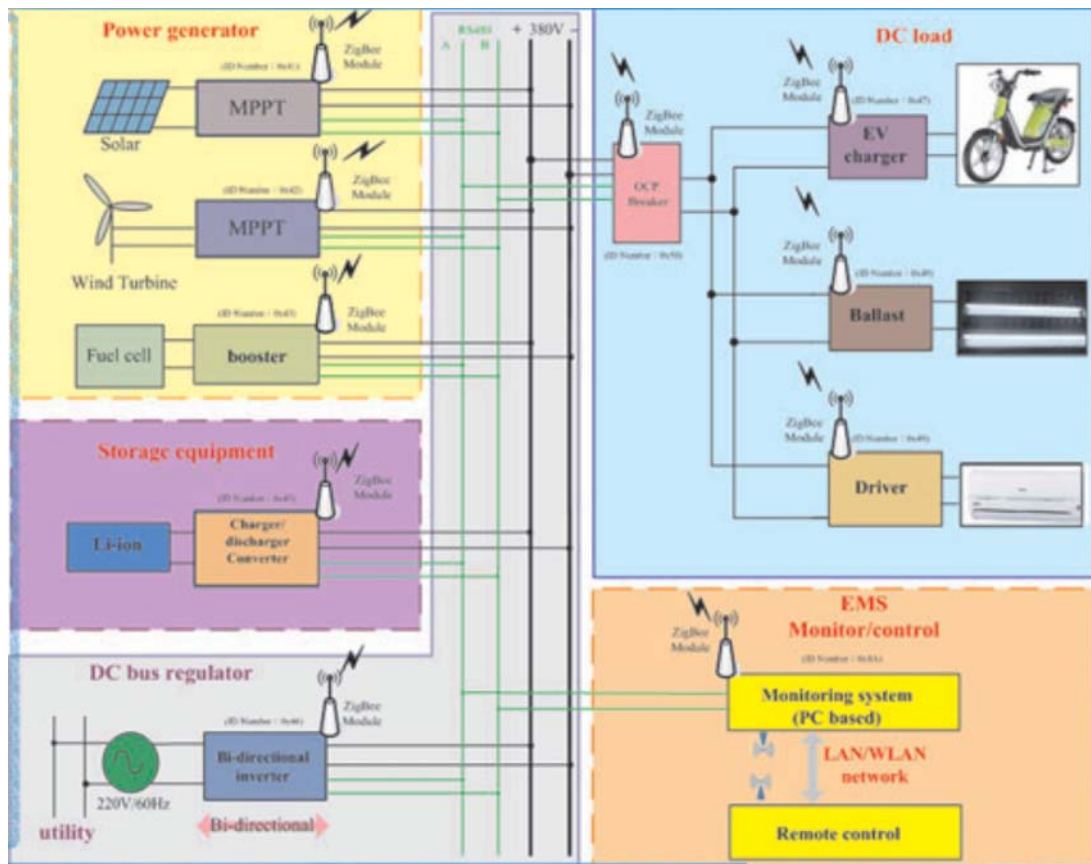

Fig. 3. Designed DC Grid with EMS

- providing power quality for our present Technology needs.
- accommodating all the generation and storage options.
- Enabling new products, services, and markets.
- Optimizing assets and operating efficiently.

The most widely undertaken are smart metering projects, followed by a variety of projects in the customer smart appliances, distribution automation, then wide-area monitoring for improved awareness in transmission systems, and the distributed renewable generation and micro grids.

Fig.3 shows the dc microgrid system with Energy Management System in this proposal, composed of Photo voltaic Energy, wind power generation, lithium-ion battery, dc load, and ac/dc converter. The proposed EMS was commanded with ZigBee/ Wi-fi / Wimax network for data communication between the grid and consumer and delivery of energy distribution instructions. The design concept of this study was to increase the useful life of lithium-ion batteries and to include the charge and over discharge protection mechanisms principle.

From Fig. 3, the system configuration includes five major blocks: 1. power generation, 2. energy storage equipment, 3. DC bus regulator, DC Fuel filling station load, and Energy Management System (EMS). The power generation typically includes PV panels, wind turbines, and fuel cells. The fuel cells provide base power for the emergency loads when the generating station is in power failure or due to any cause. Maximum power point trackers are associated with PV panels and wind turbines to draw a maximum power from the particular maximum region, which is fed to the dc grid. The dc fuel filling station and dc loads are connected to the dc grid and supplied from the grid directly. If there is any power shortage, the bidirectional inverter will take power from the ac grid and it is operated in rectification mode with output as regulated DC with power factor correction to regulate the dc-grid voltage with a range from 380 ± 20 V. When there is a power failure in the power generation to the grid, the Li-ion battery will be initially discharged to supply power for a very short-time interval and if the power failure lasts longer than 3-4 min, then fuel cell will start supplying the power to the DC grid. It is important to see

that the battery discharger will be also responsible for dc-grid voltage regulation if the Bidirectional inverter is not in operation Mode. If the bidirectional inverter is in operation Mode, then the battery can be charged by getting from the ac source by Rectification. If there is residual power on the dc grid, the battery can be charged depending on the battery Status by its capacity of charge stored through EMS, or the bidirectional inverter can be operated in grid-connection mode to sell power and regulate dc-grid voltage 380 ± 20 V. The overall system operation will be monitored and controlled by the Energy Management System (EMS), so each module of the system has to communicate with the EMS based on Wi-Max / Wi-Fi / ZigBee communication protocol. The EMS will command the Battery Modules when to operate and collect operational status of Charging or Discharging. Although, in emergency situation, an excessive current, voltage or temperature high or low, the modules will protect themselves without a command from the EMS, but the modules will communicate to the EMS of their current status. The fuzzy control is set to optimize energy distribution and to set up the battery state of charge parameters. The control algorithm takes the priority of distributing electricity as the premise of energy distribution to allow remaining power generated by the renewable energy of the electrical grid.

A. Power Production Control

For Non-conventional generation, megawatt (MW) output is controlled at four levels. The first level, also called automatic generation control (AGC), provides regulation and load following and is centralized for a designated region of the network called the balancing area (BA); it regulates power production of all the units in the (Balanced Area) BA, typically pulsing units every 3-4 s, in response to steady-state deviations in frequency, and tie line power flow to neighboring BAs. The third level typically operates every 5-6 min to set each Renewable energy basepoint power production level to optimize the BA's economic objective via an algorithm called the security-constrained economic dispatch (SCED) for stable. The fourth level operates every day regularly to provide next-day 24-h power plant schedules in terms of their hourly interconnection status (high or low) and approximate dispatch via another optimization algorithm called the security-constrained unit commitment (SCUC). All control levels are motivated to provide continuous

power balance, with first two levels and also providing frequency control and last two levels providing economic optimization.

B. Generation Uncertainty

Regular Renewable Energy production have Variable Generations (VGs) which vary by system, mostly the generation uncertainty it is by the natural and the physical cause. The Photovoltaic Plant and Windmill Plant which have energy conversions by means of high intensity of light in Panel with MPPT and wind mill which also don't have an continuous wind naturally so there it all depend on the nature of the light intensity and wind speed. Variable Generations (VGs) which takes place in the real time. Variable Generations (VG) which depends on the 24–48h between VG resource forecasts, and real-time VG offers depend on 5–60 min ahead Variable Generation (VGs) resource forecasts. The error associated with these forecasts causes uncertainty in VG schedules.

C. Regulation of Frequency

Frequency has been controlled strictly to avoid activation of under and under frequency load (UFL) or above frequency Load (AFL). This kind of approach gives control for frequency deviation before it hits the UFL or AFL set points. These control performance standards require balancing areas (BA) to meet required frequency control performance in terms of metrics based standards on frequency error statistics in regulation. Increasing VG penetration levels degrades this performance. Adjustment of future frequency performance standards may be considered as the penetration level of VG Increases. Also, the ability of wind turbine generators to emulate the inertia of traditional generators is an interesting Frequency regulation impact to explore.

V. CONSUMER INVOLVEMENT

A. Smart Homes, Business, and Industrial Parks

smart grid development in the consumer domain is in full variation characteristics. Smart appliances which are used by the consumer are equipped with controllers to maximize efficiency and to control the power flow and are widely available. The appliances which are used by the customer have various interfaces with the energy management system to select from the interface and users can also set the energy savings programs from a centralized location, such as a

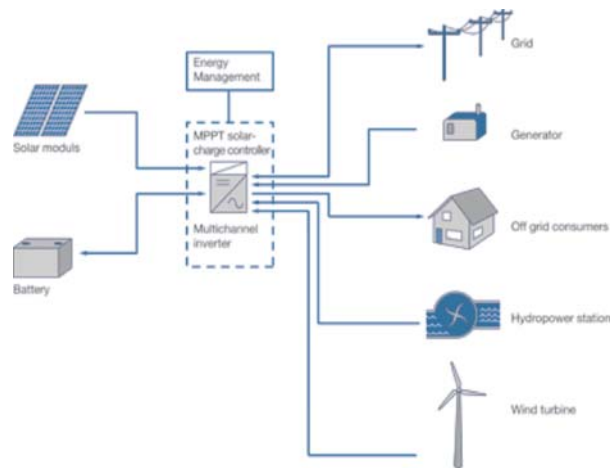

Fig. 4.0 Multi Channel inverter for smart Grid by EMS

residential or business premises. Now, the use of smart appliances is guided by the energy savings in a given locality or premise. In India, the energy efficient rating has been given by five star rating that the appliance which have more energy saving and it also consume less energy which Rating of the appliance is given by Bueareu of energy Efficiency (BEE). Bueareu of Energy Efficiency in india they encourage the manufacturers for producing the five star rated efficient energy and less loss for appliances. In Consumer the load used by the consumer vary by their using of an appliance at an different time by the different consumer which are also being noted, e.g., where in the appliance are turn themselves on and off as the frequency in the system deteriorates / improves making the appliances act as an automated controller for demand control. Bueareu of Energy Efficiency in India which sets an energy management systems and energy management standards in Indian consumer by setting an energy manager and energy auditor in different sector of several industry. Building energy management systems have been in use for many years but the level of sophistication they offer now makes them complex and effective. Energy management system not only focused on energy use, but also on managing information about carbon footprint, aggregation with other. Buildings in directly controllable building clusters, and on. Online monitoring of the ventilation, lighting, and water and fire systems. To permit building managers to utilize the full benefits, several manufacturers have recently introduced the new concept of dashboard information integration and

sharing for building energy management control. Further extension of the smart grid concept that encourages expansion of the customer owned electricity infrastructure leads to as micro grids .The main advantage of micro grid is local grid development with various means of generation, energy storage options, and multiple load types all optimized for local energy efficiency and capable of self controlled as well as integrated operation with the main grid. Such benefits are often found on various types of campuses such as universities, hospitals, industrial parks, in islands, IT Parks, military bases, and shopping centers where a large number of buildings or other loads are concentrated in a relatively small geographical area, and local electricity generation is also available for full integration in such a local grid for supply of the loads with a micro smart grid.

VI. MULTILEVEL INVERTER TOPOLOGY IN EMERGING TRENDS

A. Hybrid Multilevel Cells

For high-power high voltage applications, it is very feasible to implement a multilevel inverter. A diode-clamped multilevel inverters or capacitor-clamped multilevel inverters will replace the full-bridge cell in a cascaded H bridge multi level inverter .This is because it reduce the amount of separate dc sources.The cascaded multilevel inverter which doesnot not need any clamping diodes or capacitor which makes the circuit much compact and easier than the diode clamped and flying capacitor multilevel inverter. If a three-level inverter replaces the full-bridge cell, the voltage level is effectively doubled for each cell then voltage for each cell will be $2V_{dc}$.

To achieve the same nine voltage levels for each phase, only two separate dc sources are needed for one phase leg and six for a three-phase Inverter. The configuration can be considered as having mixed-level hybrid multilevel cells because it embeds multilevel cells as the building block of the cascaded inverter. It is very clear that a diode-clamped inverter can replace the capacitor-clamped inverter to be a mixed-level hybrid multilevel cell.

B. Asymmetric Hybrid Multilevel Cells

In previous descriptions, the voltage levels of the cascaded inverter cells equal each other.It is possible to have different voltage levels among the cells [21], [22], and the circuit can be called as asymmetric Hybrid

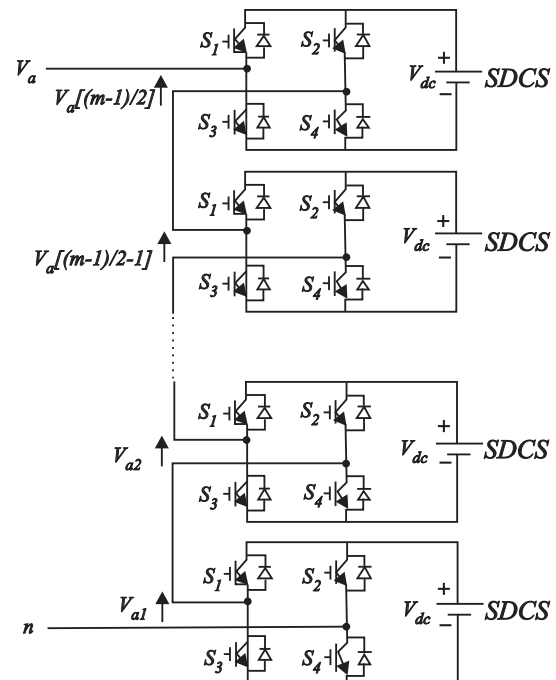

Fig. 5. Cascaded multilevel inverter with separate DC source

multilevel inverter. The diode-clamped and capacitor-clamped multilevel inverters can be derived from this general inverter topology. The general multilevel inverter topology can be balanced to each voltage level by itself regardless of load characteristics. Therefore, the general multilevel inverter topology provides a true multilevel structure that can balance each dc voltage level automatically to any number of levels, regardless of active or reactive power conversion, and without any assistance from other circuits. In principle, it provides a complete multilevel topology that embraces the existing multilevel inverters.

Any inverter with any number of levels, including the conventional two-level inverter can be obtained using this generalized topology. As an application example, a four-level bidirectional dc/dc converter, suitable for the dual-voltage system to be adopted in automobiles. The four-level dc/dc converter has a unique feature, which is that no magnetic components are needed. From this generalized multilevel inverter topology, several new multilevel inverter structures can be derived [21].

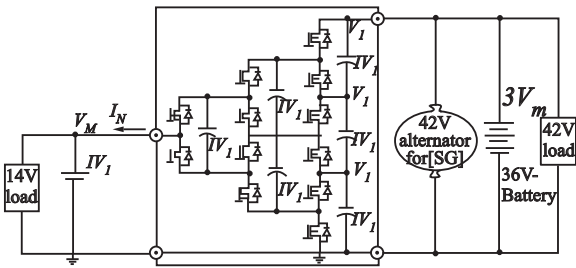

Fig. 6. Application example: a four-level P2 converter for the dual-voltage system in automobiles.

C. Cascaded Multicell Inverters

A different converter topology is introduced here, which is based on the series connection of single-phase inverters with separate DC sources. Fig. 4 shows the power circuit for one phase leg of a nine-level inverter with four cells in each phase. The resulting phase voltage is synthesized by the addition of the voltages generated by the different cells. Each single-phase full-bridge inverter generates three voltages at the output: +, 0, and -. This is possible by connecting the capacitors sequentially to the AC side via the four power switches. The resulting output AC voltage with nine levels, and the staircase waveform is nearly sinusoidal, even without filtering. In order for the inverter output voltages to be added up, the inverter outputs of the three modules need to be synchronized with a separation of 120° between each phase. For example, obtaining a three-level voltage between outputs *a* and *b*, the voltage is synthesized by the addition of the voltages generated by the different cells. The phase between *a* and *b* is provided by and through an isolated transformer. With three inverters synchronized, the voltages are all in phase; thus, the output level is simply tripled. Let us describe the multilevel inverter simulation diagram which is done by the Simulink with subsystem which is shown in Fig 7.0.

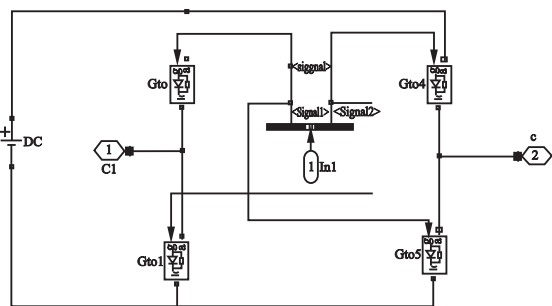

Fig. 7.0 Cascaded full bridge multilevel inverter

For converting from DC grid to AC consumer here in this paper described about the thirteen level multilevel inverter for AC output without harmonics and losses by increasing the number of staircase waveform with reference to the sinusoidal waveform and filter component is also not necessary by using the thirteen level cascaded Hybrid Multilevel inverter shown in Fig.9. The modulation methods used in multilevel inverters can be classified according to switching frequency, as shown in Fig. 8. Methods that work with high switching frequencies have many commutations for the power semiconductors in one period of the fundamental output voltage. A very popular method in industrial applications is the classic carrier-based sinusoidal PWM (SPWM) that uses the phase-shifting technique to reduce the harmonics in the load voltage [20], Another interesting alternative is the SVM strategy, which has been used in three-level inverters [20]. Methods that work with low switching frequencies generally perform one or two commutations of the power semiconductors during one cycle of the output voltages, generating a staircase waveform. Representatives of this family are the multilevel selective harmonic elimination, [21] and the space-vector control (SVC) [23].

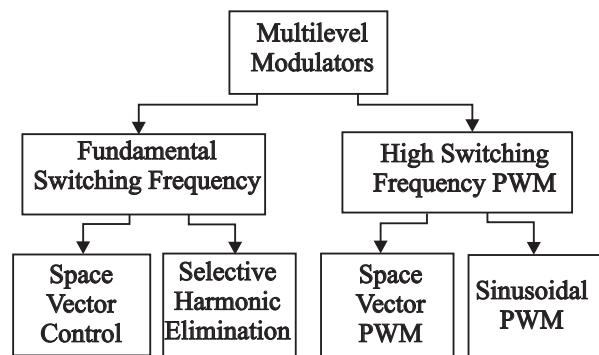

Fig. 8. Classification of multilevel modulation methods.

Distributed energy systems, mostly using alternative energies such as photovoltaic panels and fuel cells, can be easily configured with a separate source connected through the power conversion circuits used as an energy module or building block to provide individual output. A cascaded inverter can then be configured with multiple modules. Such a system does not need a transformer to provide isolation, and the system can be constructed in a cost effective manner.

VII. SIMULATION RESULTS

Distributed energy systems, mostly using alternative energies such as photovoltaic panels and fuel cells, can be easily configured with a separate source connected through the power conversion circuits used as an energy module or building block to provide individual output. A cascaded inverter can then be configured with multiple modules. Such a system does not need a transformer to provide isolation, and the system can be constructed in a cost effective manner. the thirteen level multilevel inverter for AC output without harmonics and losses by increasing the number of staircase waveform with reference to the sinusoidal waveform and filter component is also not necessary by using the thirteen level cascaded Hybrid Multilevel inverter shown in Fig.10

A. Proposed Model

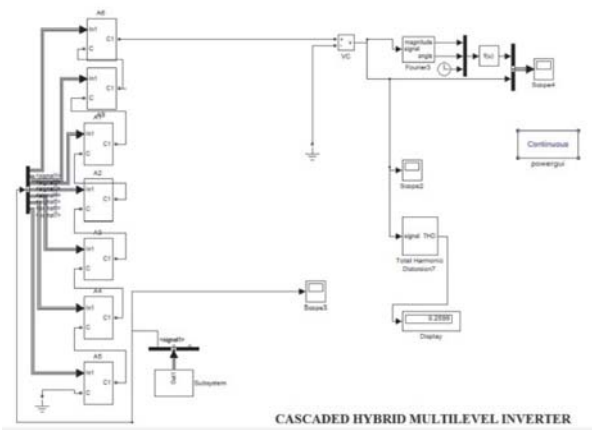

Fig. 9. Thirteen level cascaded H Bridge Multilevel inverter

B. Simulation Output

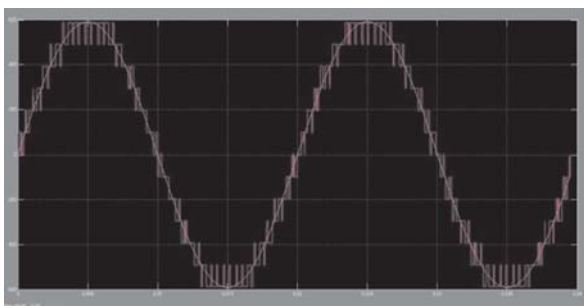

Fig. 10 Simulation result for thirteen level multilevel inverter represents stair case wave with respect to the sine wave.

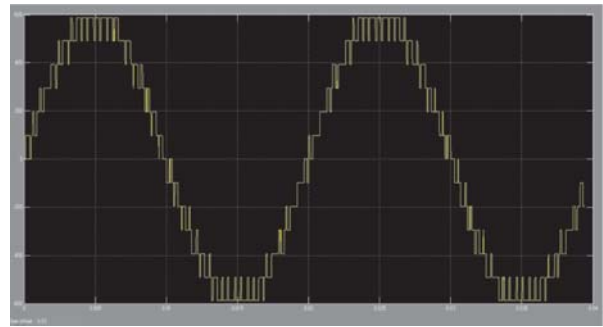

Fig. 11 Simulation result for thirteen level multilevel inverter represents stair case wave

C. Simulation of Solar Model

Solar cells are connected in series and parallel to set up the solar array. Solar cell will produce dc voltage when it is exposed to sunlight Solar cell can be regarded as a non-linear current source. Its generated current depends on the characteristic of material, age of solar cell, irradiation and cell temperature.

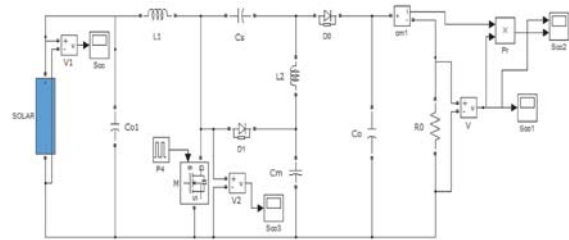

Fig. 12. Simulation of the solar model

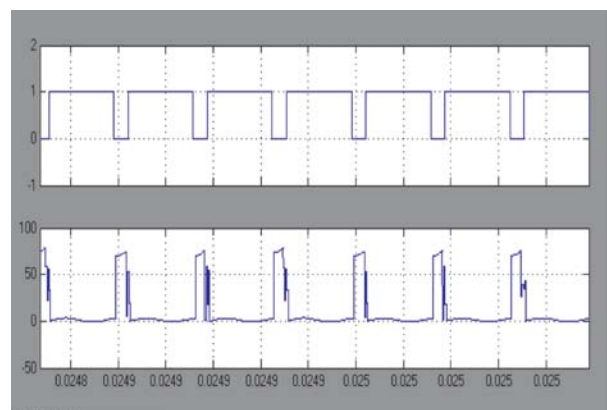

Fig. 13. simulation result of gate pulse and switch voltage of solar model (1v/division,50v/division and 0.1ms/division)

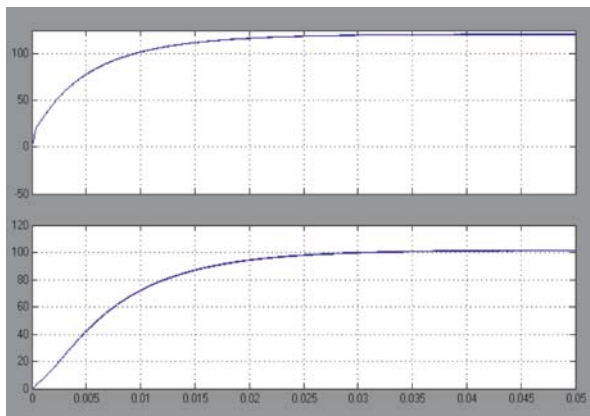

Fig. 14. Output voltage and output power of the solar model (50v/division, 20w/division and 5ms/division)

VIII. CONCLUSION

An Emerging Future trend of DC Smart Grid Connected with Hybrid Multilevel inverter and DC Fuel Charging Station Which plays a major role for Charging PHEV, EV and DC battery. The main aim of this paper is reveal a solution for future trends and technology to provide efficient Renewable Energy through DC Smart grid and to overcome the power outages. In PHEV, EV, integrated chargers are used which have drive and inverter model. Cascaded Multilevel inverter is used for ac output tp the consumer from DC Grid .Smart Grid which have a communication between the module of source and fuel charging station.Simulation results have been presented to verify the features of proposed topology. In future, it can implement in grid system, real time application.

REFERENCES

- [1] Wai R.J. and Duan R.-Y., 2009 "High step-up converter with coupled-inductor, *IEEE Trans. Power Electron.*, vol. 20, no. 5, pp. 1025–1035,.
- [2] Karki. R., Billinton R., 2008 "Reliability/cost implications of PV and wind energy utilization in small isolated power systems," *IEEE Trans. On Energy Conversion*, vol. 16, issue 4, pp. 368-373,.
- [3] Morcos M. M., Dillman N. G., and Mersman C. R., 1993, "Battery chargersfor electric vehicles," *IEEE Power Eng. Rev.*, vol. 20, no. 11, pp. 8–11,Nov. 18, 2000.[2] C. C. Chan and K. T. Chau, "Power electronics challenges in electricvehicles," in *Proc. IEEE IECON*, Nov. 15–19, vol. 2, pp. 701–706.
- [4] Emadi A., Lee Y. J., and Rajashekara K., 2008. "Power electronics and motor drives in electric, hybrid electric, and plug-in hybrid electric vehicles," *IEEE Trans. Ind. Electron.*, vol. 55, no. 6, pp. 2237–2245.
- [5] Khan I.A., 1994, "Battery chargers for electric and hybrid vehicles," in *Proc.Power Electron. Transp.*, Oct. 20–21, pp. 103–112.
- [6] Hayes J. G., 1998, "Battery charging systems for electric vehicles," in *Proc. Inst. Elect. Eng. Colloq. Elect. Veh.—A Technology Roadmap for the Future (Digest No. 1998/262)*, May 5, pp. 4/1–4/8.
- [7] Mapelli F. L., Tarsitano D., and Mauri M., 2010. "Plug-in hybrid electric vehicle: Modeling, prototype realization, and inverter losses reduction analysis," *IEEE Trans. Ind. Electron.*, vol. 57, no. 2, pp. 598–607,
- [8] Gomez J. C. and Morcos M. M., Jul. 2003 "Impact of EV battery chargers on the power quality of distribution systems," *IEEE Trans. Power Del.*, vol. 18, no. 3, pp. 975–981, .
- [8] van Hoek H., Boesing M., van Treek D., Schoenen T., and De Doncker R. W., 2010, "Power electronicarchitectures for electric vehicles," in *Proc. Elect. Power Train—Emobility*, Nov. 8–9, pp. 1–6.
- [9] Vazquez S., Lukic S. M., Galvan E., Franquelo L. G., and Carrasco J. M., 2010 "Energy storage systems for transport and grid applications," *IEEE Trans.Ind. Electron.*, vol. 57, no. 12, pp. 3881–3895,.
- [10] Amjadi and S. S. Williamson, 2010. " Power - electronics - based solutions for plug-in hybrid electric vehicle energy storage and management systems," *IEEE Trans. Ind. Electron.*, vol. 57, no. 2, pp. 608–616,
- [11] Dixon J., Nakashima I., Arcos E. F., and Ortuzar M. , 2010. "Electric vehicle using a combination of ultracapacitors and ZEBRA battery," *IEEE Trans. Ind. Electron.*, vol. 57, no. 3, pp. 943–949,.
- [12] Prudente M., Pfitscher L. L., Emmendoerfer G., Romanelli E. F. R., and Gules R., 2008 "Voltage multiplier cells applied to non-isolated DC–DC converters," *IEEE Trans. Power Electron.*, vol. 23, no. 2, pp. 871–887,.
- [13] Amei K., Takayasu Y., Ohji T., and Sakui M., 2002 "A Maximum Power Control of Wind Generator System Using PMSG and a Boost ChopperCircuit," in *Proc. IEEE Power Conversion Conference*
- [14] Datta R. and Ran gan athan V. T., 2003, "A Method of Tracking the Peak Power Points for a Variable Speed WECS," *IEEE Trans. On Energy Conversion*, 163 - 168, vol. 18.
- [15] Habib M.A. , Said S.A. M. , El-Hadidy M.A. and AlZaharna. 1999 "Optimization of hybrid photovoltaic wind energy system". Vol. 24,929.

- [16] Nehrir M. H., Lameres B. J., Venkataramanan G., Gerez V., Alvarad L. A. 2000. "An approach to evaluate the general performance of standalone wind/photovoltaic generating systems," IEEE Trans. on Energy Conversion, vol. 15, no. 4, pp. 433-439,
- [17] Kroposki B., Lasseter R., Ise T., Morozumi S., Papatlianassiou, and N. Hatziaargyriou, Making microgrids work, [IEEE Power Energy Mag., vol. 6, no. 3, pp. 40-53, May/Jun. 2008.
- [18] KEMA. 2010,. Research evaluation of wind generation, solar generation, and storage impact on the California grid, Rep. EC-500-2010-010.
- [19] Zhang Z. and Deshu C., 1991. BAn adaptive approach in digital distance protection, [IEEE Trans. Power Delivery, vol. 6, no. 1, pp. 135-142, Jan.
- [20] Rockefeller G. D., Wagner C. L., Linders J. R., K. L. Hicks, and D. T. Rizy, 1988. BAdaptive transmission relaying concepts for improved performance, [IEEE Trans. Power Delivery, vol. 3, no. 4, pp. 1446-1458.
- [21] Lai J. S. and Pen F. Z., May/June 1996 " Multilevel converters—A new breed of power converters," IEEE Trans. Ind. Applicat., vol. 32, pp. 509-517, .
- [22] Tolbert L., Peng F.-Z. , and Habetler T., Jan./Feb.1999 "Multilevel converters for large electric drives," IEEE Trans. Ind. Applicat., vol. 35, pp. 36-44,.
- [23] Teodorescu R., Beabjerg F., Pedersen J. K., Cengelci E., Sulistijo S., Woo B., and Enjeti P., 1999 "Multilevel converters — A survey," in ProcEuropean Power Electronics Conf. (EPE'99), Lausanne, Switzerland,.



R. Naveen Kumar received his B.E Degree in Electrical and Electronics Engineering from Institute of Road and Transport Technology, Erode. Affiliated by Anna University in 2010. He has Two Years Experience in Thermal Power Plant, worked in Thermax Limited, Pune from

2010-2012 as Control Room Engineer. In Sep 2012 he started his PG course, Power Electronic and Drives from Adhipharasakthi Engineering College, Melmaruvathur, Affiliated by Anna University.